

Panasonic®

Operating Instructions Pharmaceutical Refrigerator

MPR-1411

MPR-1411R

MPR-1411

MPR-1411R Series



MPR-1411R

Please read these instructions carefully before using this product, and save this operating instructions for future use.

See page 38 for all Model numbers.

CONTENTS

INTRODUCTION	P. 2
PRECAUTIONS FOR SAFE OPERATION	P. 3
ENVIRONMENTAL CONDITIONS	P. 7
REFRIGERATOR COMPONENTS	P. 8
Inside of front cover	P. 10
Control panel	P. 11
INSTALLATION SITE	P. 12
INSTALLATION	P. 13
START-UP OF UNIT	P. 14
STOCK OF CONTAINERS	P. 15
CHAMBER TEMPERATURE SETTING	P. 16
KEY LOCK FUNCTION	P. 16
ALARM TEMPERATURE SETTING	P. 17
SETTING OF DELAY OF DOOR ALARM	P. 18
SETTING OF ALARM RESUME TIME	P. 19
OPERATION CHECK AFTER RECOVERY	P. 19
DEFROST CYCLES	P. 20
REMOTE ALARM TERMINAL	P. 20
ALARMS & SAFETY FUNCTIONS	P. 21
ROUTINE MAINTENANCE	P. 22
Cleaning of cabinet	P. 22
Cleaning of evaporating tray	P. 22
Replacement of fluorescent lamp	P. 23
Replacement of glow starter	P. 24
Cleaning of condenser filter	P. 24
TROUBLESHOOTING	P. 25
DISPOSAL OF UNIT	P. 26
TEMPERATURE RECORDER (OPTION)	P. 31
Setting of MTR-0621LH	P. 31
Setting of MTR-G04A/MTR-G04C	P. 33
BATTERY MOUNTING BOX (OPTION)	P. 35
Setting for MPR-48B	P. 35
SPECIFICATIONS	P. 36
PERFORMANCE	P. 37
SAFETY CHECK SHEET	P. 38

INTRODUCTION

- Read this operating instructions carefully before using the appliance and follow the instructions for safety operation.
- Our company never guarantee any safety if the appliance is used for any objects other than intended use or used by any procedures other than those mentioned in this operating instructions.
- Keep this operating instructions in an adequate place to refer to it as necessary.
- The contents of the operating instructions will be subjected to change without notice due to the improvement of performance or functions.
- Contact our sales representative or agent if any page of the operating instructions is lost or page order is incorrect.
- Contact our sales representative or agent if any point in this operating instructions is unclear or if there are any inaccuracies.
- No part of this operating instructions may be reproduced in any form without the expressed written permission of our company.

CAUTION

Our company guarantees the product under certain warranty conditions. Our company in no way shall be responsible for any loss of content or damage of content.

PRECAUTIONS FOR SAFE OPERATION

It is imperative that the user complies with this operating instructions as it contains important safety advice.

Items and procedures are described so that you can use this unit correctly and safely. If the precautions advised are followed, this will prevent possible injury to the user and any other person.

Precautions are illustrated in the following way:



WARNING

Failure to observe WARNING signs could result in a hazard to personnel possibly resulting in serious injury or death.

CAUTION

Failure to observe CAUTION signs could result in injury to personnel and damage to the unit and associated property.

Symbol shows;

-  this symbol means caution.
-  this symbol means an action is prohibited.
-  this symbol means an instruction must be followed.

Be sure to keep this operating instructions in a place accessible to users of this unit.

< Label on the unit >



This mark is labeled on the cover in which the electrical components of high voltage are enclosed to prevent the electric shock.

The cover should be removed by a qualified engineer or a service personnel only.













PRECAUTIONS FOR SAFE OPERATION

WARNING

-  **Do not use the unit outdoors.** Current leakage or electric shock may result if the unit is exposed to rain water.
-  **Only qualified engineers or service personnel should install the unit.** The installation by unqualified personnel may cause electric shock or fire.
-  **Install the unit on a sturdy floor and take an adequate precaution to prevent the unit from turning over.** If the floor is not strong enough or the installation site is not adequate, this may result in injury from the unit falling or tipping over.
-  **Never install the unit in a humid place or a place where it is likely to be splashed by water.** Deterioration of the insulation may result which could cause current leakage or electric shock.
-  **Never install the unit in a flammable or volatile location.** This may cause explosion or fire.
-  **Never install the unit where acid or corrosive gases are present** as current leakage or electric shock may result due to corrosion.
-  **Always ground (earth) the unit to prevent electric shock.** If the power supply outlet is not grounded, it will be necessary to install a ground by qualified engineers.
-  **Never ground the unit through a gas pipe, water main, telephone line or lightning rod.** Such grounding may cause electric shock in the case of an incomplete circuit.
-  **Connect the unit to a power source as indicated on the rating label attached to the unit.** Use of any other voltage or frequency other than that on the rating label may cause fire or electric shock.
-  **Never store volatile or flammable substances** in this unit if the container cannot be sealed. These may cause explosion or fire.
-  **Do not insert metal objects such as a pin or a wire into any vent, gap or any outlet on the unit.** This may cause electric shock or injury by accidental contact with moving parts.
-  **Use this unit in safe area when treating the poison, harmful or radiate articles.** Improper use may cause bad effect on your health or environment.
-  **Turn off the power switch (if provided) and disconnect the power supply to the unit prior to any repair or maintenance** of the unit in order to prevent electric shock or injury.
-  **Do not touch any electrical parts (such as power supply plug) or operate switches with a wet hand.** This may cause electric shock.

PRECAUTIONS FOR SAFE OPERATION







WARNING

-  **Ensure you do not inhale or consume medication or aerosols** from around the unit at the time of maintenance. These may be harmful to your health.
-  **Never splash water directly onto the unit** as this may cause electric shock or short circuit.
-  **Never put containers with liquid on the unit** as this may cause electric shock or short circuit when the liquid is spilled.
-  **Never bind, process, or step on the power supply cord, or never damage or break the power supply plug.** A broken supply cord or plug may cause fire or electric shock.
-  **Do not use the supply cord if its plug is loose.** Such supply cord may cause fire or electric shock.
-  **Never disassemble, repair, or modify the unit yourself.** Any such work carried out by an unauthorized person may result in fire, or electric shock or injury due to a malfunction.
-  **Disconnect the power supply plug if there is something wrong with the unit.** Continued abnormal operation may cause electric shock or fire.
-  **When removing the plug from the power supply outlet, grip the power supply plug, not the cord.** Pulling the cord may result in electric shock or fire by short circuit.
-  **Disconnect the power supply plug** before moving the unit. Take care not to damage the power cord. A damaged cord may cause electric shock or fire.
-  **Disconnect the power plug when the unit is not used for long periods.** Keeping the connection may cause electric shock, current leakage, or fire due to the deterioration of insulation.
-  If the unit is to be stored unused in an unsupervised area for an extended period, **ensure that children do not have access and that doors cannot be closed completely.**
-  **The disposal of the unit should be accomplished by appropriate personnel.** Remove doors to prevent accidents such as suffocation.
-  **Do not put the packing plastic bag within reach of children** as suffocation may result.

PRECAUTIONS FOR SAFE OPERATION



CAUTION

-  **Use a dedicated power source** (a dedicated circuit with a breaker) as indicated on the rating label attached to the unit. A branched circuit may cause fire resulting from abnormal heating.
-  **Connect the power supply plug to the power source firmly after removing the dust on the plug.** A dusty plug or improper insertion may cause a heat or ignition.
-  **Never store corrosive substances such as acid or alkali** in this unit if the container cannot be sealed. These may cause corrosion of inner components or electric parts.
-  **Check the setting when starting up of operation after power failure or turning off of power switch.** The stored items may be damaged due to the change of setting.
-  **Be careful not to tip over the unit** during movement to prevent damage or injury.
-  **Prepare a safety check sheet** when you request any repair or maintenance for the safety of service personnel.

ENVIRONMENTAL CONDITIONS

This equipment is designed to be safe at least under the following conditions (based on the IEC 61010-1):

- Indoor use;
- Altitude up to 2000 m;
- Ambient temperature 5°C to 40°C;
- Maximum relative humidity 80% for temperature up to 31°C decreasing linearly to 50% relative humidity at 40°C;
- Mains supply voltage fluctuations up to $\pm 10\%$ of the nominal voltage;
- Transient overvoltages up to the levels of OVERVOLTAGE CATEGORY II;
- Temporary OVERVOLTAGES occurring on the mains supply;
- Applicable pollution degree of the intended environment (POLLUTION DEGREE 2 in most cases)

REFRIGERATOR COMPONENTS

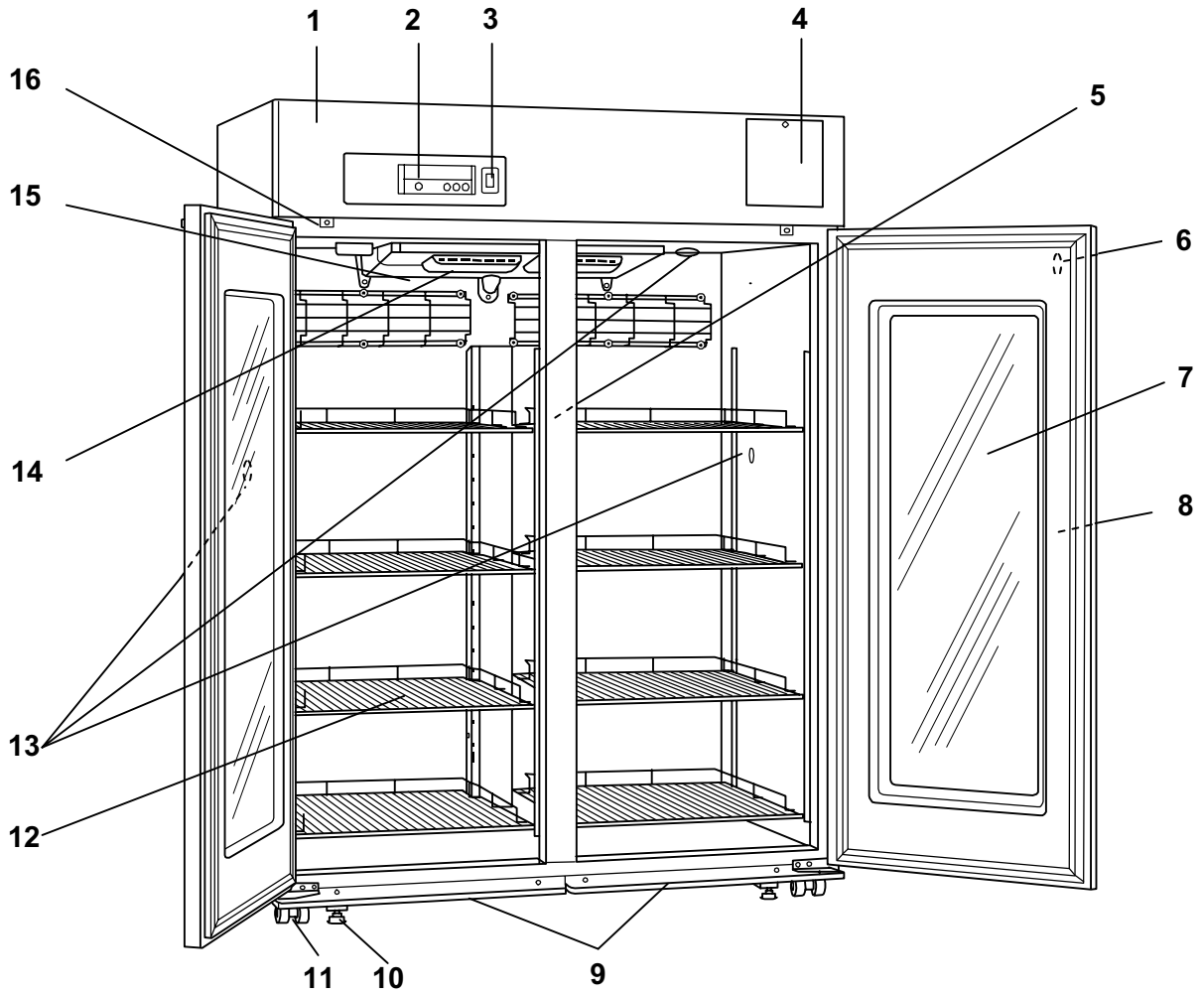

MPR-1411

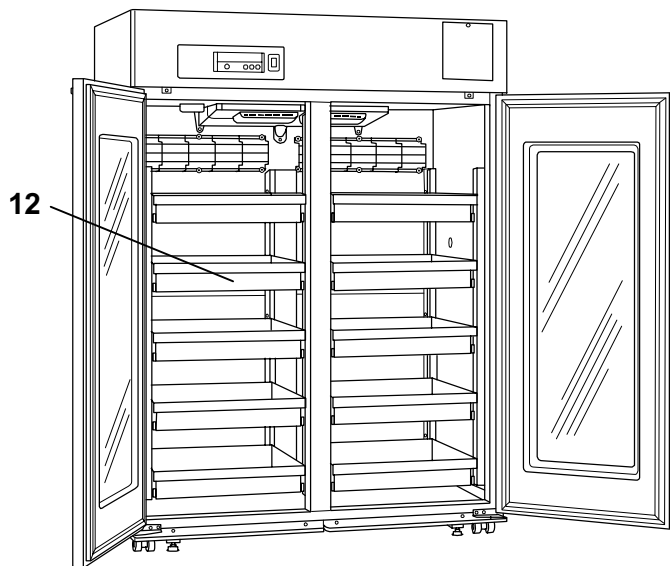

MPR-1411R

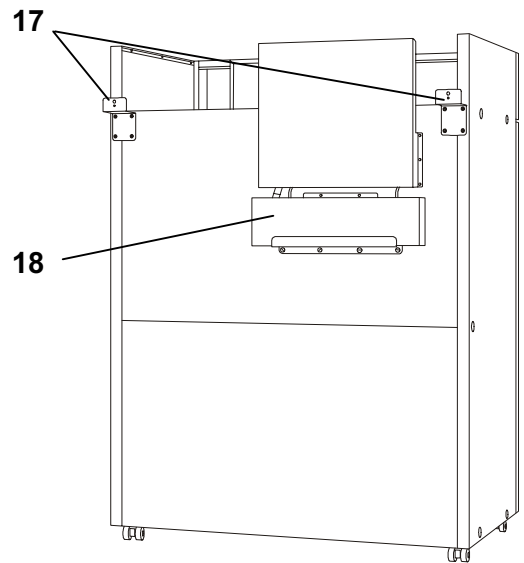

Rear side

REFRIGERATOR COMPONENTS

- 1. Front cover:** A front cover opens when a bottom part is pulled to the front. Open this cover when you use cleaning of the condenser filter, a remote alarm terminal. Refer to page 10.
- 2. Control panel:** Panel opens when the right top of the lower part cover is pushed. Refer to page 11.
- 3. Light switch:** This switch is used for turning the fluorescent lamp off and on.
- 4. Space for temperature recorder:** An temperature recorder (optional accessory) can be mounted here. See page 32.
- 5. Fluorescent lamp:** 40 W white lamp. See page 24 for replacement.
- 6. Lock:** Turn the key clockwise through 180° to securely lock the door.
- 7. Glass window:** The window may have condensation in high humidity environment. Wipe off the condensation with a soft dry cloth.
- 8. Handle:** Always hold the handle when opening/closing the door.
- 9. Dew receiver:** The condensation on the outer door is accumulated on this dew receiver. Wipe off the water on the dew receiver with a cloth.
- 10. Leveling foot:** Adjust the height of the leveling feet by turning the screw bolts until the unit is level.
- 11. Caster:** When installing the unit, the castors can be raised from the floor by using the leveling feet above.
- 12. Drawer (MPR-1411R only):** Items to be stored in the chamber must be placed on the drawers. The maximum storage weight for each drawer is 40 kg.
Shelf (MPR-1411 only): Items to be stored in the chamber must be placed on the shelves. The maximum storage weight for each shelf is 50 kg. Do not put stored items directly onto the interior floor of the chamber. See page 15.
- 13. Access port:** This port allows temperature measurement cables to enter the chamber from outside. A total of three (3) ports are provided; left side, right side and top.
- 14. Exhaust air vent:** Do not block this vent. If this vent is blocked, temperature regulation will become unstable. Do not place stored items in the path of the cold air.
- 15. Intake air vent:** Do not block this vent. If this vent is blocked, temperature regulation will become unstable. Do not insert a finger or any foreign object into this vent as there is danger from the internal fan.
- 16. Door switch:** When a door opens, a fan for the cold circulation is stopped, and the leakage of the cold is prevented. And, the check lamp of the door is turned on.
- 17. Fixture:** 2 fixtures are attached on the rear side of the unit. These keep adequate space between the unit and wall and also can be used for fixing the unit. See page 13.
- 18. Evaporating tray:** Defrost water from the evaporator accumulates on the tray and evaporates into the atmosphere. See page 23 for cleaning.

REFRIGERATOR COMPONENTS

Inside of front cover

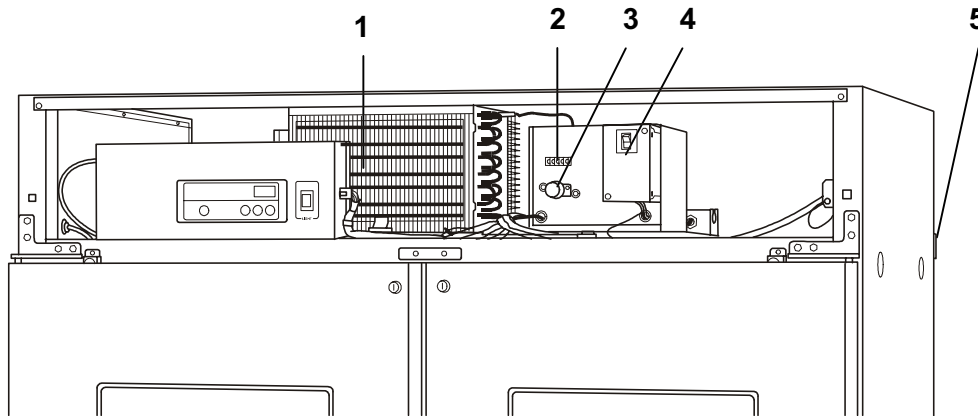

1. Condenser filter: This filter is for prevention of condenser clogged up. Clean the condenser filter every 3 month.

2. Remote alarm terminal: This is used to connect the unit to an exterior alarm to notify users of any malfunction. Refer to page 21.

3. Glow starter: This is for the fluorescent lamp. It is recommended that the glow starter is also replaced when the fluorescent lamp is replaced. Refer to page 25.

4. Circuit breaker: Make sure to switch ON this breaker before starting up of the unit. This disconnects the power when any abnormality is occurred and over current is rushed. Contact with dealer or service station after disconnect the power supply plug. Rated AC 250 V, 10 A.

5. Fixture (rear side): 2 fixtures are attached on the rear side of the unit. These keep adequate space between the unit and wall and also can be used for fixing the unit. See page 13.

REFRIGERATOR COMPONENTS

Control panel

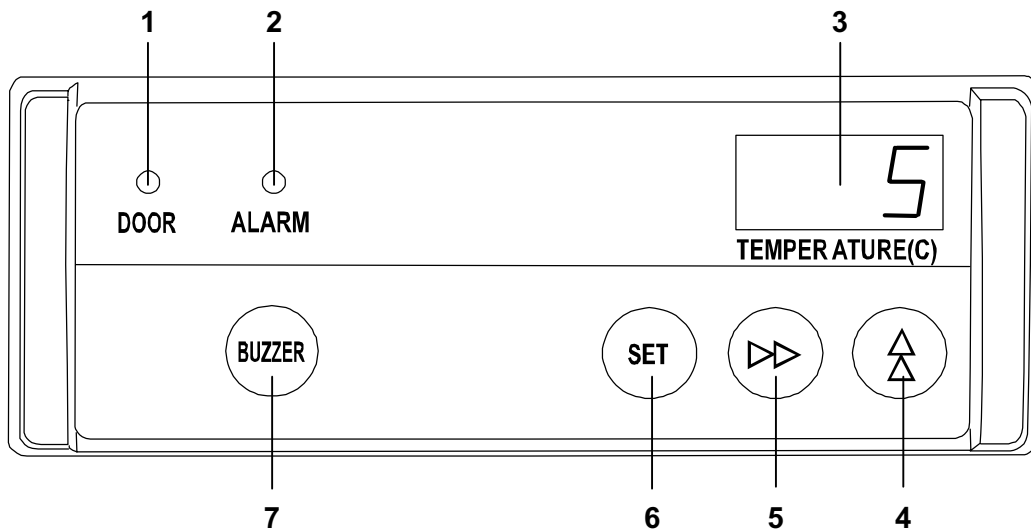

1. Door alarm lamp (DOOR): This lamp is lit when the door is opened.

2. Alarm lamp (ALARM): This lamp flashes during an alarm condition.

3. Digital temperature indicator: This indicator shows the present chamber temperature or set temperature.

4. Numerical value shift key (▲): Pressing this key in the setting mode causes the numerical value to shift. ON-OFF of key lock can be selected by pressing this key in the key lock mode. By pressing this key for more than 5 seconds in the temperature display mode leads setting mode for alarm temperature, door alarm delay time and alarm resume time. Refer to page 17,18 and 19 for details respectively.

5. Digit shift key (▶▶): Pressing this key in the setting mode causes the changeable digit to shift. Key lock mode is led by pressing this key for more than 5 seconds in the temperature display mode. Refer to page 16 for the key lock.

6. Set key (SET): Temperature setting mode is led by pressing this key. Once the key is pressed, the changeable digit is flashed.

7. Buzzer stop key (BUZZER): To silence the audible alarm, press this key. Press it once again to reactivate the alarm.

INSTALLATION SITE

To operate this unit properly and to obtain maximum performance, install the unit in a location with the following conditions:

■ **A location not subjected to direct sunlight**

Do not install the unit under direct sunlight. Installation in a location subjected to direct sunlight cannot obtain the intended performance.

■ **A location with adequate ventilation**

Leave at least 10 cm around the unit for ventilation. Poor ventilation will result in a reduction of the performance and consequently the failure.

■ **A location away from heat generating sources**

Avoid installing the unit near heat-emitting appliances such as a heater or a boiler etc. Heat can decrease the intended performance of the unit.

■ **A location with little temperature change**

Install the unit under stable ambient temperature. The allowable ambient temperature is between -5 and +35°C.

■ **A location with a sturdy and level floor**

Always install the unit on a sturdy and level floor. The uneven floor or tilted installation may cause failure or injury. Install the unit in stable condition to avoid the vibration or noise. Unstable condition may cause vibration or noise.

 **WARNING**

Install the unit on a sturdy floor. If the floor is not strong enough or the installation site is not adequate, this may result in injury from the unit falling or tipping over.

Select a level and sturdy floor for installation. This precaution will prevent the unit from tipping. Improper installation may result in water spillage or injury from the unit tipping over.

■ **A location not prone to high humidity**

Install the unit in the ambient of 80% R.H. or less humidity. Installation under high humidity may cause current leakage or electric shock.

 **WARNING**

Do not use the unit outdoors. Current leakage or electric shock may result if the unit is exposed to rain water.

Never install the unit in a humid place or a place where it is likely to be splashed by water. Deterioration of the insulation may result which could cause current leakage or electric shock.

■ **A location without flammable or corrosive gas**

Never install the unit in a flammable or volatile location. This may cause explosion or fire or may result in the current leakage or electric shock by the corrosion of the electrical components.

■ **A location without the possibility of anything fall**

Avoid installing the unit in the location where anything can fall down onto the unit. This may cause the breakdown or failure of the unit.

INSTALLATION

1. Removing the packaging materials and tapes

Remove all transportation packaging materials and tapes. Open the doors and ventilate the unit. If the outside panels are dirty, clean them with a diluted neutral dishwashing detergent. (Undiluted detergent can damage the plastic components. For the dilution, refer to the instruction of the detergent.) After the cleaning with the diluted detergent, always wipe it off with a wet cloth. Then wipe off the panels with a dry cloth.

Note:

Remove the cable tie for banding the power supply cord. Prolonged banding may cause the corrosion of the cord coating

2. Adjusting the leveling foot

Extend the leveling feet by rotating them counterclockwise until they make contact with the floor. (Fig. 1) Ensure the unit is level.

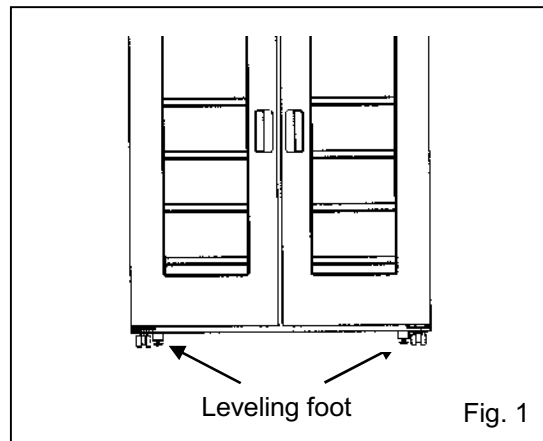

3. Fixing the unit

Two fixtures are attached to the rear of the frame. Fix the frame to the wall by attaching a rope or chain between the wall and the fixtures. (Fig. 2)

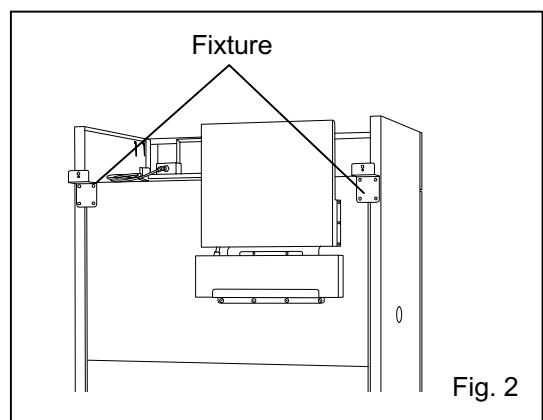

4. Ground (earth)

The ground (earth) is for preventing the electric shock in the case of the electrical insulation is somehow degraded. Always ground the unit at the time of installation.

⚠ WARNING

Use a power supply outlet with ground (earth) to prevent electric shock. If the power supply outlet is not grounded, it is necessary to install a ground by qualified engineers.

Never ground the unit through a gas pipe, water main, telephone line or lightning rod. Such grounding may cause electric shock in the case of an incomplete circuit.

START-UP OF UNIT

Follow the procedures for the initial and consequent operations of the unit.

1. Connect the power cord to the dedicated outlet with appropriate rating.

CAUTION

If the unit is unplugged or the power to the unit is interrupted, do not restart the unit for at least 5 minutes. This protects the compressor.

2. On start-up, the alarm buzzer sometimes operates. In this case, stop the buzzer by pressing the alarm buzzer stop key (BUZZER).
3. Set the chamber temperature to 5°C.
4. Allow the chamber temperature to fall to 5°C. Check the chamber temperature on the temperature indicator.
5. Turn on the fluorescent light switch to check the light. After checking, turn off the switch if the light is not necessary.
6. Set the desired temperature. When the chamber temperature gets to the set temperature, begin slowly placing items into the chamber to minimize the temperature rise.

CAUTION

The chamber is refrigerated by the forced circulation of cooled air inside the chamber. Ensure that the intake and exhaust air vents are not blocked. Adequate space should be provided between the items inside the unit to allow air circulation.

<Attention>

The outer door has a condensation on the glass during refrigerator operation. Wipe off the condensation with a dry soft cloth. Also, wipe off the water on the dew receiver regularly.

STOCK OF CONTAINERS

Always distribute items so as not to disturb the air circulation in the chamber. Disruption of the air flow can cause items to freeze or reduce the uniformity of the chamber temperature. Never put any articles on the top of the unit.

Air intake vent

Do not block this vent with containers. If this vent becomes blocked, temperature regulation becomes unstable. Do not place paper or vinyl near the vent as they may be sucked into the fan.

Exhaust air vent

Do not block this vent with containers as this can impede air circulation. Items stored near the exhaust air vent can freeze when the refrigerator is operating at temperature settings lower than 5°C.

Load line

In this refrigerator, storage space is limited to allow the passage of cool air around the chamber. The label "load line" is fixed to both sides of the chamber. Always stock items within this line.

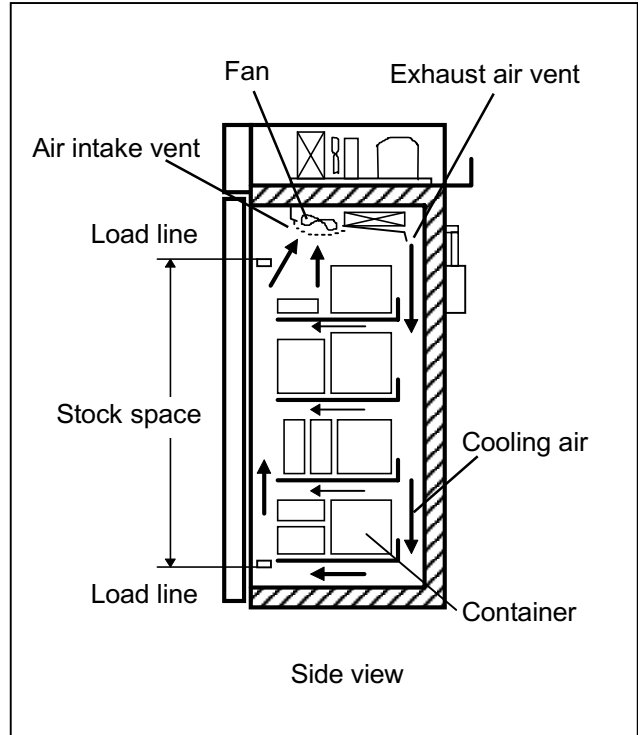

⚠ CAUTION





Never store corrosive substances in this unit. This may lead to damage to the inner components or electric parts.

CHAMBER TEMPERATURE SETTING

Table 1 shows the basic procedure for setting the chamber temperature. Perform key operations in the sequence indicated in the table. The example in the table is based on the assumption that the desired temperature is 4°C.

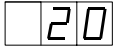
Note: The unit is set at the factory with a chamber temperature of 5°C.

Table 1 Basic operation sequence (Example: Chamber set temperature 4°C)

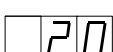
	Description of operation	Key operated	Indication after operation
1	Turn the power switch ON.	----	The current chamber temperature is displayed. 
2	Press set key.	SET	The first digit is flashed. 
3	Press numerical value shift key and scroll the figure to 4.		When pressed, the figure of settable digit changes. 
4	Press set key.	SET	Set temperature is memorized and the current chamber temperature is displayed. 

Note:

The temperature set mode returns to the temperature display mode automatically when 90 seconds has passed without any key operation. In this case, the chamber temperature setting is not accepted.







The available set range of chamber temperature is between 2°C and 23°C. The partial freezing may occurred if the set temperature is lower than 3°C.

KEY LOCK FUNCTION

This unit is provided with a key lock function. When the key lock is ON, change of temperature setting through the key pad is not available. The key lock is set in OFF at the factory.

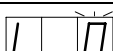
Display	Mode	Function
L 0	Key lock is OFF	Enable to change of temperature setting
L 1	Key lock is ON	Disable to change of temperature setting

Table 2 Procedure for key lock setting (change from key lock OFF to key lock ON)

	Description of operation	Key operated	Indication after operation
1		----	The current chamber temperature is displayed. 
2	Press digit shift key for 5 seconds.		The first digit is flashed. 
3	Press numerical value shift key and scroll the figure to 1.		When pressed, the figure of settable digit changes. 
4	Press set key.	SET	The key lock is set to ON. The current chamber temperature is displayed. 

The key lock set mode returns to the temperature display mode automatically when 90 seconds has passed without any key operation.

ALARM TEMPERATURE SETTING

This unit is provided with both high and low temperature alarms. The temperature at which the alarm is activated may be changed.

The available set range for high temperature alarm is between +2°C and +14°C and -2°C and -14°C for low temperature alarm against the chamber temperature.

Note: The temperature alarm is set at $\pm 5^\circ\text{C}$ of the set temperature at the factory.

Display	Mode	Function
F01	High temperature alarm set	See Table 3 on page 17
F02	Low temperature alarm set	See Table 4 on page 17

As an example, Table 3 shows the procedure to set the high temperature alarm so that the alarm can activate when the chamber temperature is 3°C higher than the set temperature.

Table 4 shows the procedure to set the low temperature alarm so that the alarm can activate when the chamber temperature is 3°C lower than the set temperature.

Table 3 Procedure for setting high temperature alarm (Change from 5°C to 3°C)

	Description of operation	Key operated	Indication after operation
1		---	The current chamber temperature is displayed.
2	Press numerical value shift key for 5 seconds.		The first digit is flashed.
3	Press numerical value shift key and scroll the figure to 1.		When pressed, the figure of settable digit changes.
4	Press set key.	SET	The first digit is flashed.
5	Set the temperature to 003 with the digit shift key and numerical value shift key.		Pressing the key shifts the digit which can be set.
			When pressed, the figure of settable digit changes.
6	Press set key.	SET	Alarm temperature is memorized and the current chamber temperature is displayed.

Table 4 Procedure for setting low temperature alarm (Change from -5°C to -3°C)

	Description of operation	Key operated	Indication after operation
1		---	The current chamber temperature is displayed.
2	Press numerical value shift key for 5 seconds.		The first digit is flashed.
3	Press numerical value shift key and scroll the figure to 2.		When pressed, the figure of settable digit changes.
4	Press set key.	SET	The first digit is flashed.
5	Set the temperature to -03 with the digit shift key and numerical value shift key.		Pressing the key shifts the digit which can be set.
			When pressed, the figure of settable digit changes.
6	Press set key.	SET	Alarm temperature is memorized and the current chamber temperature is displayed.

The alarm temperature set mode returns to the temperature display mode automatically when 90 seconds has passed without any key operation.

SETTING OF DELAY OF DOOR ALARM

The door check indicator is light when the door is opened, and the alarm buzzer sounds with some delay to notice the door opening.

The delay time (between lighting of the door check indicator and activation of the alarm buzzer) can be changed. Set an appropriate delay time according to the condition of use to prevent the rise of chamber temperature resulting from inadequate door close.

(The available set range of delay time is between 1 and 15 minutes. Initial setting (factory setting) is 2 minutes.)

Table 5 Procedure for setting of delay of door alarm (Change the delay time to 3 min. from 2 min.)

	Description of operation	Key operated	Indication after operation
1		-----	The current chamber temperature is displayed.
2	Press numerical value shift key for 5 seconds.		F00 is displayed and the first digit flashed.
3	Press numerical value shift key 4 times.		The display is changed to F04 from F00.
4	Press set key.	SET	The current setting (002) is displayed and the first digit flashed.
5	Press numerical value shift key and scroll the figure to 003.		The display is changed to 003 from 002.
6	Press set key.	SET	Delay time is memorized and the current chamber temperature is displayed.

Note:

- The door alarm delay time set mode returns to the temperature display mode automatically when 90 seconds has passed without any key operation.

SETTING OF ALARM RESUME TIME

The alarm buzzer and remote alarm are silenced by pressing the alarm buzzer stop key (BUZZER) on the control panel during alarm condition. The buzzer and remote alarm will be activated again after certain suspension if the alarm condition is continued. The suspension time can be set by following the procedure shown in the Table 6 below.

The example in the table is based on the assumption that the desired duration is 20 minutes.

Note: The duration is set in 30 minutes at the factory.

Table 6 Procedure for setting of alarm resume time (Example: change from 30 minutes to 20 minutes)

	Operation	Key operated	Indication after operation
1		----	The current chamber temperature is displayed.
2	Press and hold the numerical value shift key for about 5 seconds.		The first digit of the temperature display flashed.
3	Set to F25 by using digit shift key and numerical value shift key.		Pressing the key leads the change of flashed digit.
			Pressing the key shifts up the figure of the current digit.
4	Press the set key.	SET	The current set value is displayed and the second digit of the temperature display flashes.
5	Set to 020 by using numerical value shift key.		Pressing the key shifts up the figure in the second digit.
6	Press the set key.	SET	The value is stored in memory and the current chamber temperature is displayed.

Note:

- The settable alarm resume times are 10, 20, 30, 40, 50, or 60 minutes (The set values are 010, 020, 030, 040, 050, and 060). The buzzer would not resume if the resume time is set in 000.
- The alarm resume time set mode returns to the temperature display mode automatically when 90 seconds has passed without any key operation.

OPERATION CHECK AFTER RECOVERY

After recovery from a power failure, the unit will resume operation automatically with the setting before power failure. Accordingly, there is no need for re-set however, always check the running status after recovery.

- The set value is memorized by nonvolatile memory during power failure.

DEFROST CYCLES

There is no need for routine defrosting of the unit as this occurs automatically as follows:

- **Cycle defrost**

When the ambient humidity is high, or a large amount of damp product is being stored inside the chamber, there is a possibility that cycle defrost may not be enough to remove all of the frost on the evaporator. In this case, a forced defrost cycle can be initiated.

- **Forced defrost**

When the unit is operating under a forced defrost cycle, the current chamber temperature and dF is displayed alternately on the digital temperature display. The chamber temperature rises about 10°C during the defrosting.

⚠ CAUTION

The unit may collect excessive frost on the evaporator if it is installed in high temperature and high humidity location. For example, the unit starts to defrost once a week with 2°C setting in the ambient of 35°C and 80% R.H. **The chamber temperature goes up to approximately 10°C temporarily during defrosting.**

REMOTE ALARM TERMINAL

The remote alarm terminal is located inside the front cover. The alarm is generated from this terminal. The contact capacity is DC 30 V, 2 A.

Contact output:

	Between COM and N.O.	Between COM and N.C.
At normal condition	“Open”	“Close”
At abnormal condition	“Close”	“Open”

Note:

The alarm is actuated when the power failure or the power cord is disconnected from the outlet.

The remote alarm is silenced by pressing the buzzer stop key (BUZZER) as the remote alarm is operated in conjunction with the buzzer

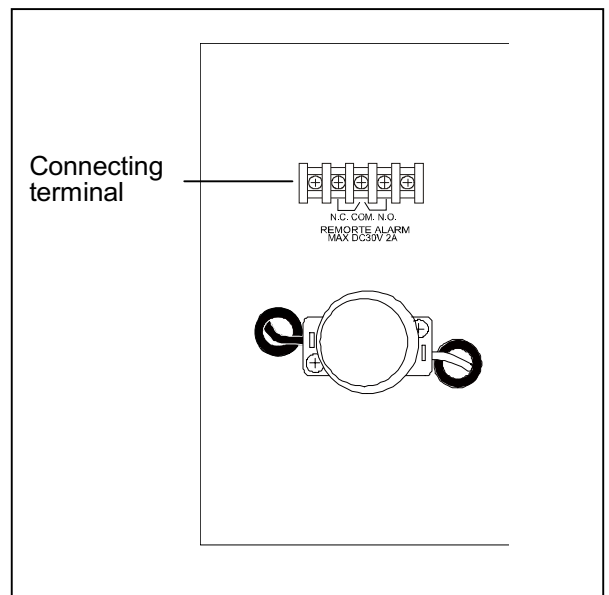

ALARMS & SAFETY FUNCTIONS

This unit has the alarms and safety functions shown in Table 7, and also self diagnostic functions.

Table 7 Alarms and safety functions

Alarm & Safety	Situation	Indication	Buzzer	Safety operation
High temperature alarm	If the chamber temperature deviates from the set temperature +2°C or up to +14°C.	Alarm lamp is flashed. Chamber temperature is flashed.	Intermittent tone with about 15 minutes delay.	Remote alarm with about 15 minutes delay.
Low temperature alarm	If the chamber temperature deviates from the set temperature -2°C or up to -14°C.	Alarm lamp is flashed. Chamber temperature is flashed.	Intermittent tone with about 15 minutes delay.	Remote alarm with about 15 minutes delay.
	If the chamber temperature is lower than 0°C.		Intermittent tone	Remote alarm
Over-heat protection	When the chamber temp. is higher than 40°C. (Reset when the chamber temp. is lower than 30°C)	----	----	Inside fan, drain pan heater, defrost heater, drain pipe heater OFF
Over-cooling protection	When the chamber temp. is lower than -1°C. (Reset when the chamber temp. is higher than 6°C)	----	----	Compressor OFF
Power failure alarm	When the power to the unit is disconnected.	----	----	Remote alarm.
Power failure alarm (with MPR-48B)	At power failure. If the power supply cord is unplugged.	Alarm lamp blinks.	Intermittent tone	Alarm status.
Door alarm	When the door is open.	Door check lamp is lit.	Intermittent tone with about 2 minutes delay.	----
Auto-return	When there is no key pressing in each setting mode for 90 seconds.	Chamber temperature is displayed.	----	Finishing of each setting mode.
Key lock	When the key lock is "ON".	----	----	Change of setting is disable.
Sensor abnormality	If the thermal sensor is disconnected.	Alarm lamp is flashed. E01 and 50°C (or -50°C) are displayed alternately.	Intermittent tone	Remote alarm. Unit keeps continuous running.
	If the thermal sensor is short-circuited.	Alarm lamp is flashed. E02 and 50°C (or -50°C) are displayed alternately.	Intermittent tone	Remote alarm. Unit keeps continuous running.
	If the defrost sensor is disconnected.	Alarm lamp is flashed. E03 and chamber temp. are displayed alternately.	Intermittent tone	Remote alarm.
	If the defrost sensor is short circuited.	Alarm lamp is flashed. E04 and chamber temp. are displayed alternately.	Intermittent tone	Remote alarm.
	If the compressor sensor is disconnected.	Alarm lamp is flashed. E05 and chamber temp. are displayed alternately.	Intermittent tone	Remote alarm.
	If the compressor sensor is short-circuited.	Alarm lamp is flashed. E06 and chamber temp. are displayed alternately.	Intermittent tone	Remote alarm.
Battery switch check (with MPR-48B)	When the battery switch is turned ON without setting after attachment.	E09 and chamber temp. is displayed alternately.	----	----
Condenser temp. abnormality	In the event of failure of fan motor for cooling the compressor	E10 and chamber temp. are displayed alternately.	Intermittent tone	Remote alarm. Compressor of high stage side stops.
Battery check (with MPR-48B)	When about 3 years have passed with the power switch on. (time to replace the battery)	F-1 and chamber temp. is displayed alternately.	----	----
Fan motor check	When about 6 years have passed with the power switch on. (time to replace the fan motor)	F-2 and chamber temp. is displayed alternately.	----	----

Note:

The alarm status of remote alarm terminal is cancelled by pressing the alarm buzzer stop key (BUZZER) since the remote alarm is operated in conjunction with alarm buzzer. (except for power failure alarm status).

When more than two alarm conditions occur simultaneously, the lowest number error code has priority on the error display.

After a power failure, the unit will resume operation with the set value that was in place before power failure occurred.

The over-cooling protection may activate when the set temperature is 2°C. In this case, the chamber temperature will rise to 6°C, but this is not malfunction

ROUTINE MAINTENANCE

⚠ WARNING

Always disconnect the power supply to the unit prior to any repair or maintenance of the unit in order to prevent electric shock or injury.

Ensure you do not inhale or consume medication or aerosols from around the unit at the time of maintenance. These may be harmful to your health.

⚠ CAUTION

Always wear dry gloves to protect hands at the time of maintenance. Failure to wear gloves may result in injury from edges and corners.

Cleaning of cabinet

- Clean the unit once a month. Regular cleaning keeps the unit looking new.
- Use a dry cloth to wipe off small amounts of dirt on the outside and inside of the unit and all accessories. If the outside panels are dirty, clean them with a diluted neutral dishwashing detergent. (Undiluted detergent can damage the plastic components. For the dilution, refer to the instruction of the detergent.) After the cleaning with the diluted detergent, always wipe it off with a wet cloth. Then wipe off the cabinet or accessories with a dry cloth.
- Never pour water onto or into the unit. Doing so can damage the electric insulation and cause failure.
- The compressor and other mechanical parts are completely sealed. This unit requires absolutely no lubrication.

Cleaning of evaporating tray

The evaporating tray is installed on the back on of the unit. Clean the evaporating tray once a month.

1. Remove the tray fixture under the evaporating tray by unscrewing 4 screws and the evaporating tray is free. (Fig. 1)
2. Wash away any accumulated dirt in the evaporating tray.
3. Fix the evaporating tray with the tray fixture and 4 screws.

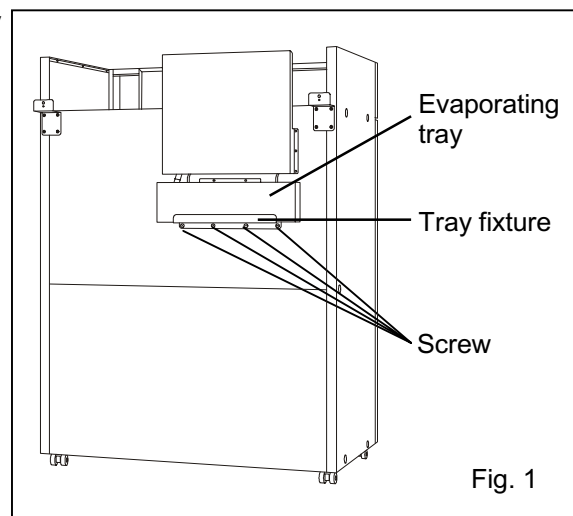

ROUTINE MAINTENANCE

Replacement of fluorescent lamp

The fluorescent lamp is placed vertically at the center of the chamber. Follow the procedure below to replace the lamp.

1. Turn off the fluorescent light switch and disconnect the power supply plug.
2. Remove all shelves or drawers.
3. In the case of MPR-1411R, remove the rail that is placed horizontal at the center of the frame.
4. Pull the lamp toward the rear together with the cover as shown in Fig. 1, together with the wiring.
5. Take out the lamp and remove the connector water-proof rubber at both ends. As shown in Fig. 2, shift the rubber by rolling it.
6. Take out the lamp by pulling it gently from the cover. Refer to Fig. 3.
7. After replacing a new lamp, return the lamp with cover to the original position.

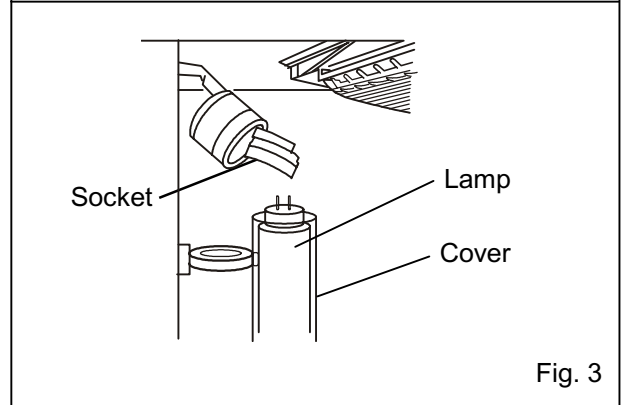
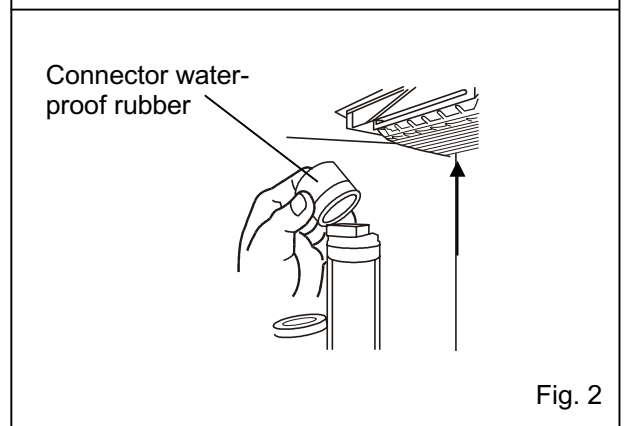
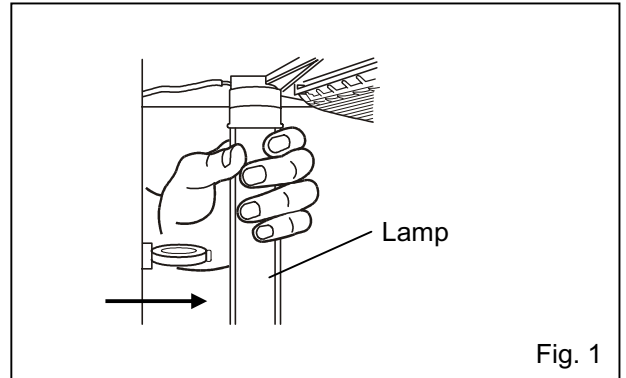

ROUTINE MAINTENANCE

Replacement of glow starter

A glow starter is located inside the front cover.

1. Disconnect the power supply plug.
2. Remove the water-proof rubber.
3. Remove the glow starter and replace with a new one.
4. Replace the water-proof rubber.

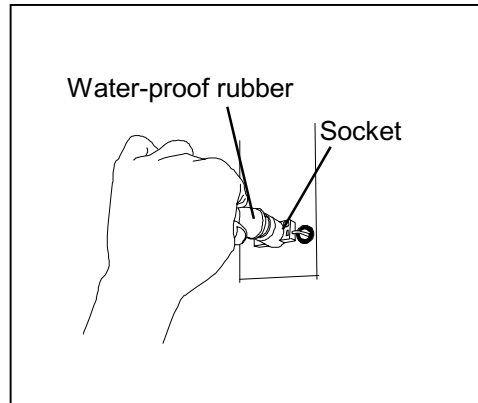

Cleaning of condenser filter

1. Lift the front cover as shown in the figure.
2. Take out the shaft and insert the end of the shaft in the black hole of the front cover.
3. After holding black handle of condenser filter, and having raised it aloft, remove the condenser filter.
4. Absorb a dirt of condenser filter with leaning machine, or wash it away with water.
5. Cut water of condenser filter well when used water.
6. After cleaning the condenser filter, return it to the original position.

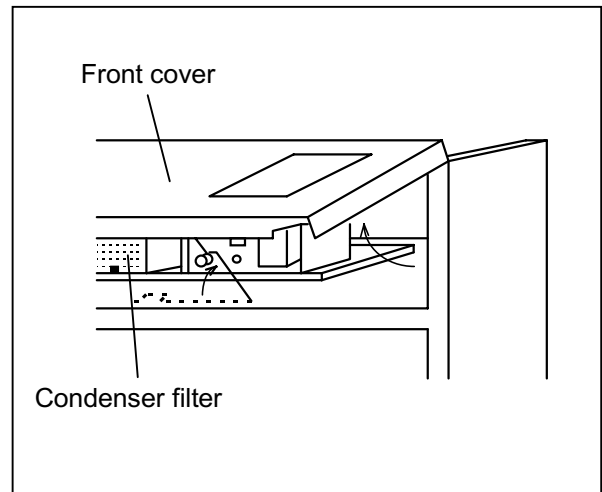

TROUBLE SHOOTING

If the unit malfunctions, check out the following before calling for service.

Malfunction	Check/Remedy
If nothing operates even when switched on	<ul style="list-style-type: none"> ▪ There is a power failure. ▪ The circuit breaker is activated. ▪ The unit is not connected to the power supply.
When no key operation is available	<ul style="list-style-type: none"> ▪ The key lock is set in ON (L 1).
The alarm device is activated	<p>< On start-up ></p> <ul style="list-style-type: none"> ▪ The temperature in the unit does not match the set value. <p>< In use ></p> <ul style="list-style-type: none"> ▪ The door was kept opened for a long time. ▪ The temperature setting was changed. ▪ The containers of high temperature (load) were put in the unit. <p>In these cases, alarm is removed automatically by running the unit for several hours.</p>
When unit does not get cold enough	<ul style="list-style-type: none"> ▪ A large amount of items or warm product was put in the unit. ▪ The air exhaust vent is blocked up with containers. ▪ The unit is in direct sunlight. ▪ The door is frequently opened. ▪ There is a nearby heat source. ▪ The ambient temperature is too high. ▪ The door is not securely closed. ▪ The heat source is put in the unit. ▪ The door seal is damaged or foreign substance is inserted between door gaskets.

Note:

If the malfunction is not eliminated after checking the above items, or the malfunction is not shown in the above table, contact our sales representative or agent.

DISPOSAL OF UNIT

 **WARNING**

If the unit is to be stored unused in an unsupervised area for an extended period **ensure that children do not have access and doors cannot be closed completely.**

The disposal of the unit should be accomplished by appropriate personnel. Always remove doors to prevent accidents such as suffocation.

DISPOSAL OF UNIT

(English)

FOR EU USERS

The symbol mark and recycling systems described below apply to EU countries and do not apply to countries in other areas of the world.

Your Panasonic product is designed and manufactured with high quality materials and components which can be recycled and/or reused.

The symbol mark means that electrical and electronic equipment, batteries and accumulators, at their end-of-life, should be disposed of separately from your household waste.

Note:

If a chemical symbol is printed beneath the symbol mark, this chemical symbol means that the battery or accumulator contains a heavy metal at a certain concentration. This will be indicated as follows: Hg: mercury, Cd: cadmium, Pb: lead

In the European Union there are separate collection systems for used electrical and electronic equipment, batteries and accumulators.

Please, dispose of them correctly at your local community waste collection/recycling centre.

Please, help us to conserve the environment we live in!

(German)

Für EU-Staaten

Das Symbol und das erwähnte Wiederverwertungssystem gelten nur für die Länder der EU und nicht für andere Länder oder Gebiete in der Welt.

Die Produkte von Panasonic werden aus hochwertigen Materialien und Komponenten gefertigt, die sich wieder verwenden lassen.

Das Symbol bedeutet, dass elektrische oder elektronische Geräte, Batterien und Akkus am Ende ihrer Lebensdauer nicht im Haushaltsmüll entsorgt werden dürfen.

Hinweis:

Ein chemisches Zeichen unter dem Symbol bedeutet, dass die Batterie bzw. der Akku Schwermetalle in gewissen Konzentrationen enthält. Die Metalle werden wie folgt bezeichnet: Hg: Quecksilber, Cd: Kadmium, Pb: Blei

In der Europäischen Union gibt es separate Sammelstellen für elektrische und elektronische Geräte, Batterien und Akkus.

Entsorgen Sie solche Geräte bitte richtig in der kommunalen Sammelstelle bzw. im Recyclingzentrum.

Helfen Sie mit, die Umwelt in der wir leben, zu schützen.

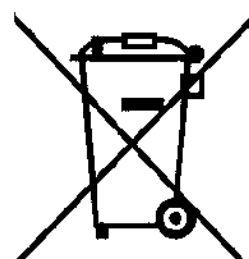

DISPOSAL OF UNIT

(French)

POUR LES UTILISATEURS DE UE

Le symbole et les systèmes de recyclage évoqués ci-dessous s'appliquent uniquement aux pays de UE.

Votre produit Panasonic est conçu et fabriqué avec des composants et des matériaux de hautes qualités qui peuvent être recyclés et/ou réutilisés.

Le symbole signifie que les équipements électriques et électroniques, les batteries et les accumulateurs ne doivent pas être mis au rebut avec les déchets domestiques à l'issue de leur durée de vie.

Remarque:

Si un symbole chimique est imprimé sous le symbole, le symbole chimique indique que la batterie ou l'accumulateur contient une certaine concentration de métaux lourds. Les métaux sont indiqués de la manière suivante: Hg: mercure, Cd: cadmium, Pb: plomb.

Il existe différents systèmes de collecte pour les équipements électriques et électroniques, les batteries et les accumulateurs usagés au sein de l'Union européenne.

Veuillez mettre les équipements au rebut de manière correcte, auprès de votre centre de recyclage/de collecte des déchets local.

Aidez-nous à préserver l'environnement dans lequel nous vivons!

Les machines ou appareils électriques et électroniques contiennent fréquemment des matières qui, si elles sont traitées ou éliminées de manière inappropriée, peuvent s'avérer potentiellement dangereuses pour la santé humaine et pour l'environnement.

Cependant, ces matières sont nécessaires au bon fonctionnement de votre appareil ou de votre machine. Pour cette raison, il vous est demandé de ne pas vous débarrasser de votre appareil ou machine usagé avec vos ordures ménagères.

(Spanish)

PARA USUARIOS DE LA UNION EUROPEA

El símbolo y los sistemas de reciclado descritos a continuación se aplican para países de la Unión Europea y no se aplica para países en otras áreas del mundo.

Su producto Panasonic fue diseñado y fabricado con materiales de alta calidad y componentes que pueden ser reciclados y/o vueltos a usar.

El símbolo significa que los equipos eléctricos y electrónicos, baterías y acumuladores, al final de su vida útil, debe ser desechados separadamente de sus residuos domiciliarios.

Nota:

Si hay un símbolo químico impreso debajo del símbolo, este símbolo químico significa que la batería o acumulador contiene una cierta concentración de un metal pesado. Esto es indicado de la siguiente manera: Hg: mercurio, Cd: cadmio, Pb: plomo

En la Unión Europea hay sistemas de recolección separados para equipos eléctricos y electrónicos, baterías y acumuladores usados.

Por favor, disponga de ellos correctamente en el centro de recolección de residuos/reciclado de la comunidad de su localidad.

Por favor, ayúdenos a proteger el medio ambiente en que vivimos!

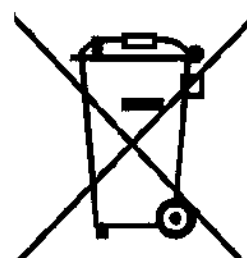

DISPOSAL OF UNIT

(Portuguese)

PARA UTILIZADORES DA UE

O símbolo e os sistemas de reciclagem descritos abaixo aplicam-se aos países da UE e não se aplicam aos países noutras áreas do mundo.

O seu produto Panasonic foi concebido e fabricado com materiais e componentes de elevada qualidade que podem ser reciclados e/ou reutilizados.

O símbolo significa que o equipamento eléctrico e electrónico, baterias e acumuladores, em final de vida, não devem ser deitados fora juntamente com o lixo doméstico.

Atenção:

Se estiver impresso um símbolo químico debaixo do símbolo de , este símbolo químico significa que a bateria ou acumulador contém um metal pesado numa determinada concentração. Estará indicado da seguinte forma: Hg: mercúrio, Cd: cádmio, Pb: chumbo

Na União Europeia existem sistemas de recolha separados para equipamento eléctrico e electrónico, baterias e acumuladores.

Por favor, entregue-os no seu centro de reciclagem/recolha de lixo local.

Por favor, ajude-nos a conservar o ambiente!

(Italian)

PER UTENTI UE

Il simbolo e i sistemi di riciclaggio descritti di seguito si applicano esclusivamente ai paesi dell'UE.

Questo prodotto Panasonic è stato progettato e realizzato con materiali e componenti di elevata qualità che possono essere riciclati e/o riutilizzati.

Il simbolo di riciclaggio mostrato di seguito indica che i dispositivi elettrici ed elettronici, le batterie e gli accumulatori, una volta esauriti, devono essere smaltiti separatamente rispetto ai rifiuti domestici.

Nota:

Se sotto il simbolo di riciclaggio appare un simbolo chimico, esso sta ad indicare che la batteria o l'accumulatore contengono metalli pesanti a determinate concentrazioni. Questo viene specificato come segue: Hg: mercurio, Cd: cadmio, Pb: piombo.

Nell'Unione europea esistono diversi sistemi per la raccolta dei rifiuti speciali quali i dispositivi elettrici ed elettronici, le batterie e gli accumulatori.

Si raccomanda di provvedere allo smaltimento di tali rifiuti secondo quanto previsto dalle normative vigenti in materia.

Aiutaci a conservare l'ambiente!

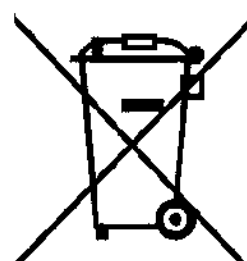

DISPOSAL OF UNIT

(Dutch)

VOOR GEBRUIKERS IN DE EU

Het symbool en de recycleersystemen die hieronder beschreven worden, zijn van toepassing op de landen in de EU en zijn niet van toepassing op landen in andere delen van de wereld.

Uw Panasonic product is ontworpen en gemaakt met materialen en onderdelen van hoge kwaliteit, die gerecycleerd en opnieuw gebruikt kunnen worden.

Het symbool betekent dat elektrische en elektronische apparatuur, batterijen en accu's aan het eind van hun leven apart van uw huisafval weggegooid moeten worden.

Let op:

Indien een chemisch symbool afgedrukt staat onder het symbool, betekent dit chemisch symbool dat de batterij of accu een zwaar metaal met een bepaalde concentratie bevat. Dit wordt als volgt aangegeven: Hg: kwik, Cd: cadmium, Pb: lood

In de Europese Unie zijn afzonderlijke inzamelingssystemen voor gebruikte elektrische en elektronische apparatuur, batterijen en accu's.

Wilt u deze op de juiste manier weggooien bij uw plaatselijk afvalinzameling-/recyclingcentrum in uw buurt?

Help ons het milieu waarin wij leven in stand te houden!

(Swedish)

FÖR ANVÄNDARE INOM EU

Den symbolmärkning och de återvinningssystem som beskrivs här nedan gäller länder inom EU och gäller inte länder i någon annan del av världen.

Din Panasonic O-produkt har konstruerats och tillverkats med delar och material av hög kvalitet, som kan återvinnas och/eller återanvändas.

Symbolmärkningen innebär att elektrisk och elektronisk utrustning, batterier och ackumulatorer, vid slutet av deras livslängd, inte får slängas som hushållsavfall utan skall slängas separat.

Observera:

Om en kemisk symbol finns tryckt under denna symbolmärkning, betyder denna kemiska symbol att batteriet eller ackumulatören innehåller en tungmetall med en viss koncentration. Detta indikeras på följande sätt: Hg: kvicksilver, Cd: kadmium, Pb: bly

I den Europeiska Unionen finns det separata uppsamlingssystem för använd elektrisk och elektronisk utrustning, batterier och ackumulatorer.

Gör dig av med sådana saker på rätt sätt på den speciella lokala platsen för återsamling/återanvändning.

Hjälp oss att bevara den miljö vi lever i!

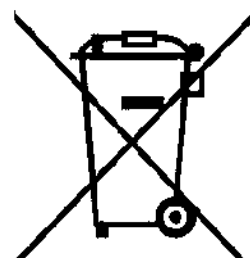

TEMPERATURE RECORDER (OPTION)

CAUTION

Always disconnect the power supply to the unit prior to attachment of a temperature recorder in order to prevent electric shock or injury.

A temperature recorder is available for this refrigerator as an optional accessory. Contact our sales representative or agent for the installation of the temperature recorder.

Temperature recorders available are the MTR-0621LH, MTR-G04A or MTR-G04C. Please note that each recorder needs a fixture. See the following for the details.

Setting of MTR-0621LH

Pull the knob on the upper part of the temperature recorder forward to change the recording paper or battery.

Setting of recording paper

1. The information on the recording paper is shown in Fig. 1.
2. Pull the cartridge up after opening the top lid. The lid can be opened by turning the knob counterclockwise. See Fig. 2.
3. As shown in Fig. 3, insert the recording paper with the "begin" tab placed in the cartridge. Check that the printed side is facing out.
4. Place the recording paper beneath the arm and between the plate spring and guide plate in the direction of the arrow.

Note:

- Do not scratch or put pressure on the recording paper.
- Do not bend the recording paper.
- Do not reverse the recording paper manually.

The used recording paper left in the used recording paper compartment can cause a malfunction. Be sure to remove it. See Fig. 4.

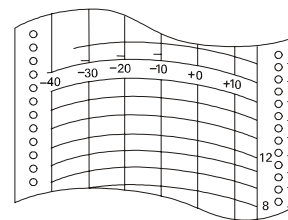

Fig. 1

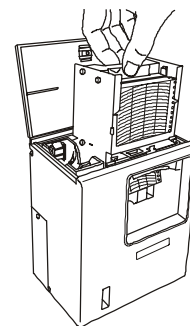

Fig. 2

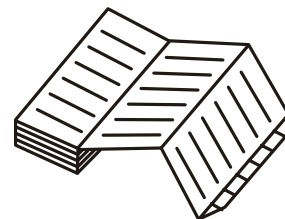

Fig. 3

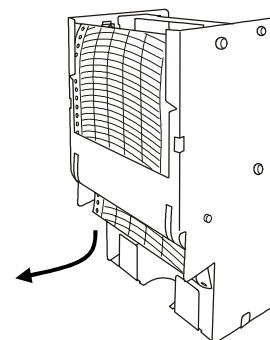

Fig. 4

TEMPERATURE RECORDER (OPTION)

5. Place the recording paper between the guide and the guide plate. Slide the recording paper along the guide plate so that the recording paper will not be forced out of the date/hour slot. See Fig. 5.

6. After ascertaining that the holes on the side of the recording paper are locked into the teeth of the sprocket, turn the gear and send the recording paper into the used chart compartment.

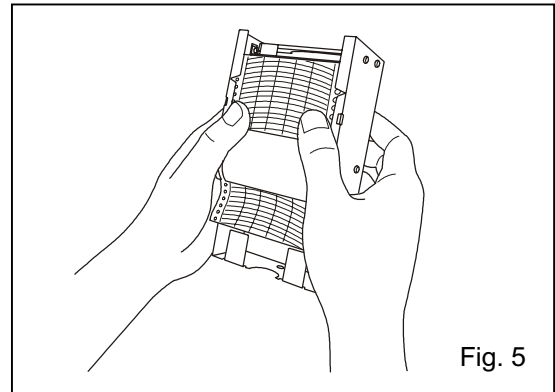

Fig. 5

Setting of time

1. Turn the gear on the date/hour slot to the desired time.
2. After properly folding the recording paper in the used or unused recording paper compartment, replace the cartridge.

Removing of the used recording paper

After recording, take out the cartridge and remove the recording paper from the recording paper outlet. If not all of the recording paper has been fed into the used recording paper compartment, send all the recording paper in the compartment first turning the gear.

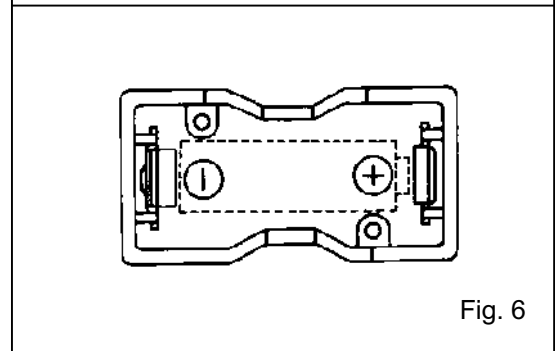

Fig. 6

Battery replacement

To replace the battery, turn the knob counterclockwise to open the lid. Place the battery in the battery case according to the plus-minus indications on the bottom of the battery case. See Fig. 6.

Note :

This temperature recorder is designed for the manganese battery and the alkaline battery.

Do not use a rechargeable battery because the initial voltage of such battery is low. The rechargeable battery may cause the malfunction of temperature recorder or shorten the battery life significantly.

Start-up

1. The quartz motor is started by placing a "R14" or size "C" battery battery in the battery case.
2. Check the operation of the temperature recorder using the quartz motor rotation check gear.
3. Replace the battery once a year.

Stopping

The temperature recorder is stopped by taking the battery out of the battery case.

TEMPERATURE RECORDER (OPTION)

Setting of MTR-G04A/MTR-G04C

WARNING

Always disconnect the power supply to the unit prior to attachment of a temperature recorder in order to prevent electric shock or injury.

If the warning is required for the internal temperature recorder or the interior temperature deviates from the target temperature, an optional temperature recorder (MTR-G04A/MTR-G04C) is available. Install the temperature recorder properly as described below.

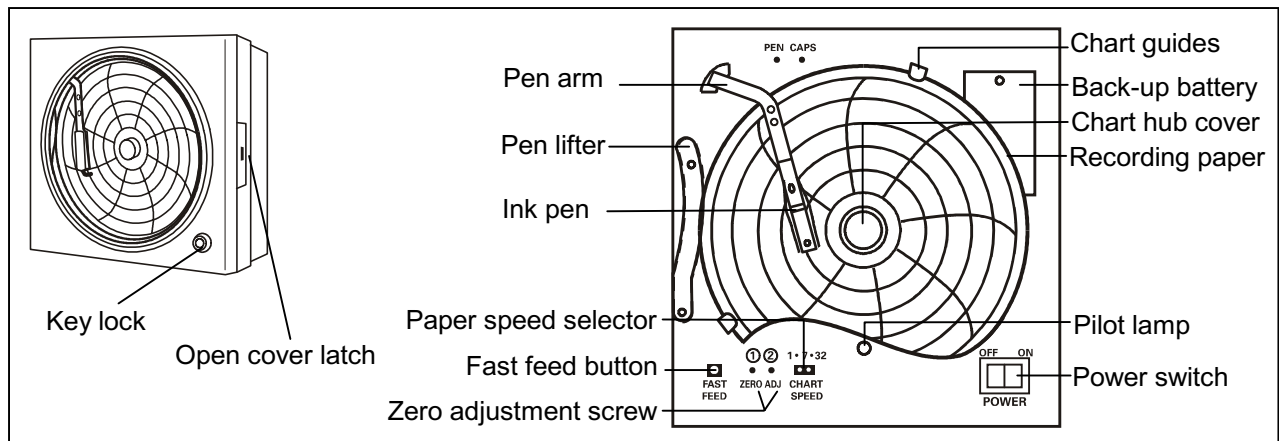

Loading the ink pen cartridge:

1. Slightly raise the end of the ink pen lifter and remove from the lifter stopper. Then rotate clockwise as shown in Fig. 1.

2. Remove the pen cartridge from the bag and remove its cap. The cap can be conveniently kept on the cap holder located at the upper left corner.

NOTE: Loading a ink pen, turn the power OFF and then ON again to return to the normal mode. (Refer to Fig. 2 when loading a ink pen cartridge.)

3. Press both sides of the pen arm as indicated by the arrows to open the head clamp at A and B. (See to Fig. 2 illustration 1)

4. Position the ink pen so that the guide pins fit into the guide holes on the pen arm. (See to Fig. 2 illustration 2)

5. Press the two sides of the head clamp as indicated by the arrows to secure the ink pen. (See to Fig. 2 illustration 3) From the side view, the cartridge should fit perfectly on the arm. Confirm that the pen arm is attached to both sides of the ink pen.

6. After loading the ink pen, return the pen lifter to the original position. Confirm that the pen lifter has securely entered the pen lifter stopper.

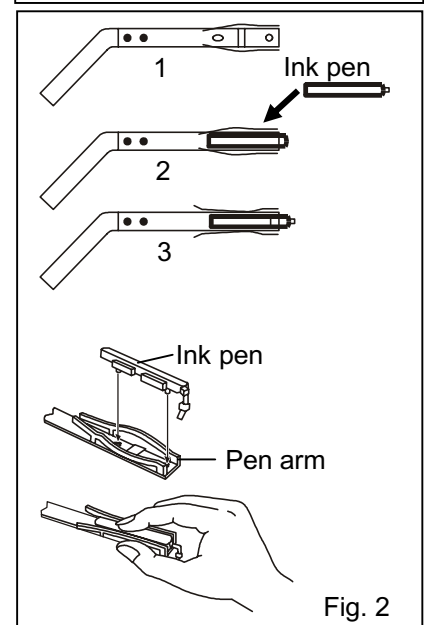
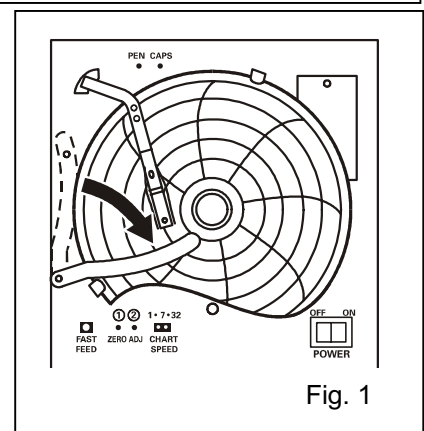

TEMPERATURE RECORDERS (OPTON)

Starting recording and setting the time:

Turn the power switch ON. The ink pen will move inward on the circular recording paper and stop temporarily at the 0% position (equivalent to the 40°C line). Then the ink pen will move to the position which indicates the measured temperature.(Fig.3)

Time setting Method:

Place the recording paper at a position slightly in front of the desired time (the chart is rotated to the left). Set the time by using the fast feed button to quickly rotate the chart.

The fast feed button can be used to accurately set the time.

When the recording paper speed is set to 32 days:

The center of the recording paper is divided into 32 equal sections. The lines extending from these lines serve as the 32-day time scale.(Fig.4)

Stopping recording:

1. Turn OFF the power switch.
2. When recording is stopped for a prescribed period, place the caps back on the ink pen to prevent the ink from evaporating.

Replacing the recording paper:

1. Slightly raise the end of the pen lifter and remove from the pen lifter stopper. Rotate the tip of the ink pen clockwise until it rests on top of the pen lifter.
2. Remove the chart hub cover, and then replace the recording paper.
3. Place the chart hub cover. Remove and dispose of the piece of paper. Confirm that the new recording paper is inside of the chart guides.
4. Set the correct time.

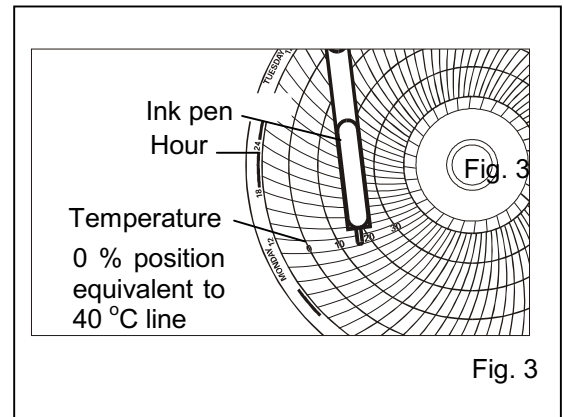

Fig. 3

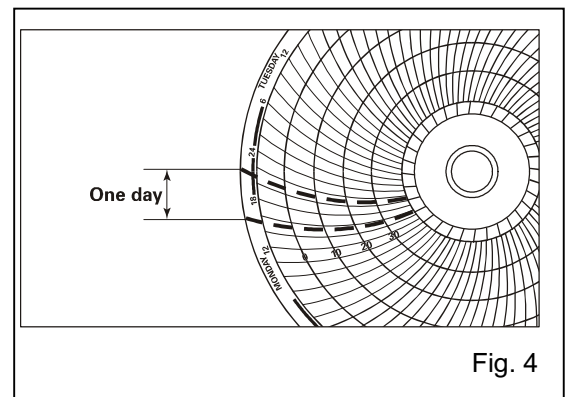

Fig. 4









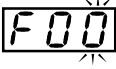

BATTERY MOUNTING BOX (OPTON)

Setting for MPR-48B

Always perform the setting shown below after the installation of battery mounting box, an optional component (MPR-48B).

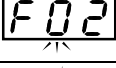
The chamber temperature and “E09” is displayed on the temperature display alternately if the battery switch is turned on without following procedure.

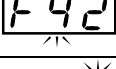
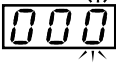
- Turn off the battery switch, perform the following setting, and turn on the battery switch again if “E09” is displayed on the temperature display.

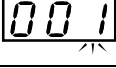
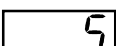
	Description of operation	Key operated	Indication after operation
1		----	The current chamber temperature is displayed. 
2	Press numerical value shift key for 5 seconds.		F00 is displayed and the first digit flashed. 
3	Press numerical value shift key twice.		The display is changed to F02 from F00. 
4	Press digit shift key once.		The second digit blinks. 
5	Press numerical value shift key 4 times.		The display is changed to F42 from F02. 
6	Press set key.	SET	The current setting (000) is displayed and the first digit flashed. 
7	Press numerical value shift key and scroll the figure to 1.		The display is changed to 001 from 000. 
8	Press set key.	SET	The setting is memorized and the current chamber temperature is displayed. 

SPECIFICATIONS

Product name	Pharmaceutical Refrigerator MPR-1411/MPR-1411R	
Model No.	MPR-1411	MPR-1411R
External dimensions	W1440 mm x D830 mm x H1950 mm	
Internal dimensions	W1320 mm x D710 mm x H1500 mm	
Effective capacity	1364 L	1359 L
Exterior	Painted steel	
Interior	Painted steel	
Door	Double layer pair glass/steel plate, automatic closing mechanism, 2 doors	
Insulation	Rigid polyurethane foamed-in place	
Shelf	Hard steel wire on polyethylene coating 8 pcs.	-----
Drawer	-----	Painted steel 10 pcs.
Access port	Left side, right side, top side, Inner diameter 30 mm	
Cooling method	Forced cool air circulation	
Compressor	Hermetic type, Output; 250 W	
Condenser	Fin and tube type	
Evaporator	Fin and tube type	
Refrigerant	R-404A	
Defrosting	Forced type, Fully automatic	
Internal heater	257 W	
Temperature controller	Microprocessor control system	
Temperature display	Digital display	
Alarm	High temp., Low temp., Door, Power failure, Over-heat and cooling protection	
Remote alarm contact	Allowable contact capacity: DC 30 V, 2A	
Memory back-up	Nonvolatile static memory	
Fluorescent lamp	White light 40 W (FL40SSECW) x 1 (Glow starter; FG-4P)	
Accessories	1 set of key, 1 nylon clip, 2 binders	
Weight	248 kg	287 kg
Optional component	Temperature recorder (MTR-0621LH), Recorder fixing (MPR-S30), Temperature recorder (MTR-G04A/MTR-G04C), Recorder fixing (MPR-S7), Battery mounting box (MPR-48B), Interface board (MTR-480, MTR-L03),	

Note: Design or specifications will be subject to change without notice.

- Refer to the updated catalog when ordering an optional component.

PERFORMANCE

Product name	Pharmaceutical Refrigerator MPR-1411/MPR-1411R			
Model No.	MPR-1411-PA MPR-1411R-PA	MPR-1411-PB MPR-1411R-PB	MPR-1411-PK MPR-1411R-PK	MPR-1411-PE MPR-1411R-PE
Cooling performance	2°C to 14°C (ambient temperature; -5°C to 0°C, no load) 2°C to 23°C (ambient temperature; 0°C to 35°C, no load)			
Temperature control range	2°C to 23°C			
Power source	AC 115 V	AC 220 V	AC 220 V	AC 230 V/240 V
Power source	60 Hz	50 Hz	60 Hz	50 Hz
Rated power consumption	380 W	355 W	375 W	360 W/370 W
Noise level	48 dB [A] (background noise; 20 dB)			
Maximum pressure	2319 kPa			

Note : The unit with CE mark complies with EC directives.

CAUTION

**Please fill in this form before servicing.
Hand over this form to the service engineer to keep for his and your safety.**

Safety check sheet

1. Refrigerator contents : Yes No
Risk of infection: Yes No
Risk of toxicity: Yes No
Risk from radioactive sources: Yes No

(List all potentially hazardous materials that have been stored in this unit.)

Notes :

2. Contamination of the unit

- Unit interior Yes No
No contamination Yes No
Decontaminated Yes No
Contaminated Yes No
Others:

3. Instructions for safe repair/maintenance of the unit

- a) The unit is safe to work on Yes No
b) There is some danger (see below) Yes No

Procedure to be adhered to in order to reduce safety risk indicated in b) below.

Date :

Signature :

Address, Division :

Telephone :

Product name : Pharmaceutical Refrigerator	Model : MPR-	Serial number :	Date of Installation :
--	-----------------	-----------------	------------------------

Please decontaminate the unit yourself before calling the service engineer.

